

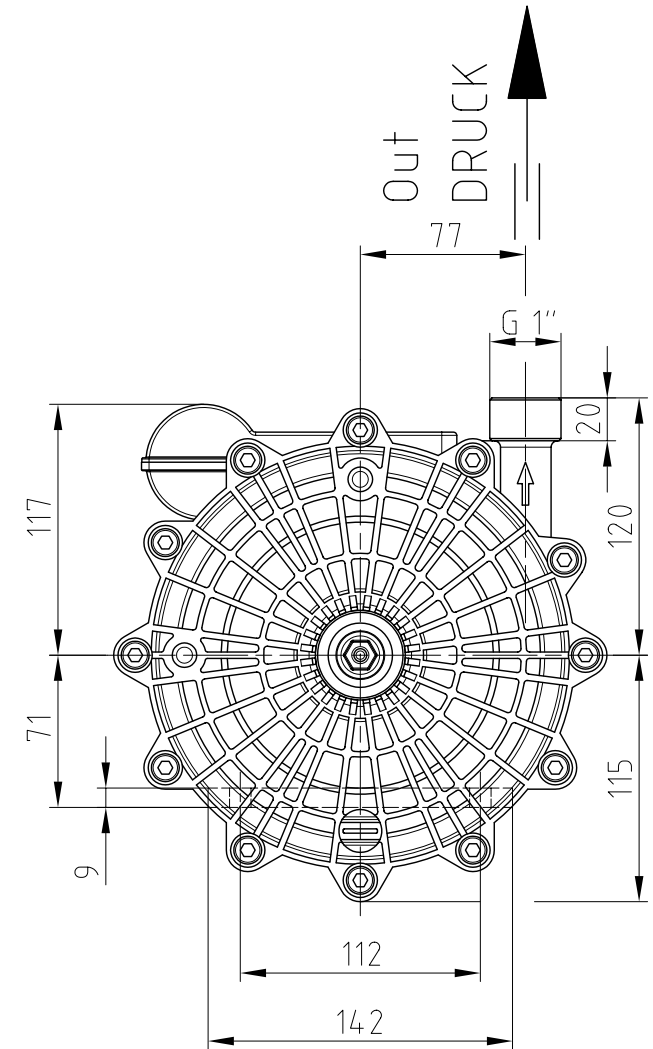

In
SAUG

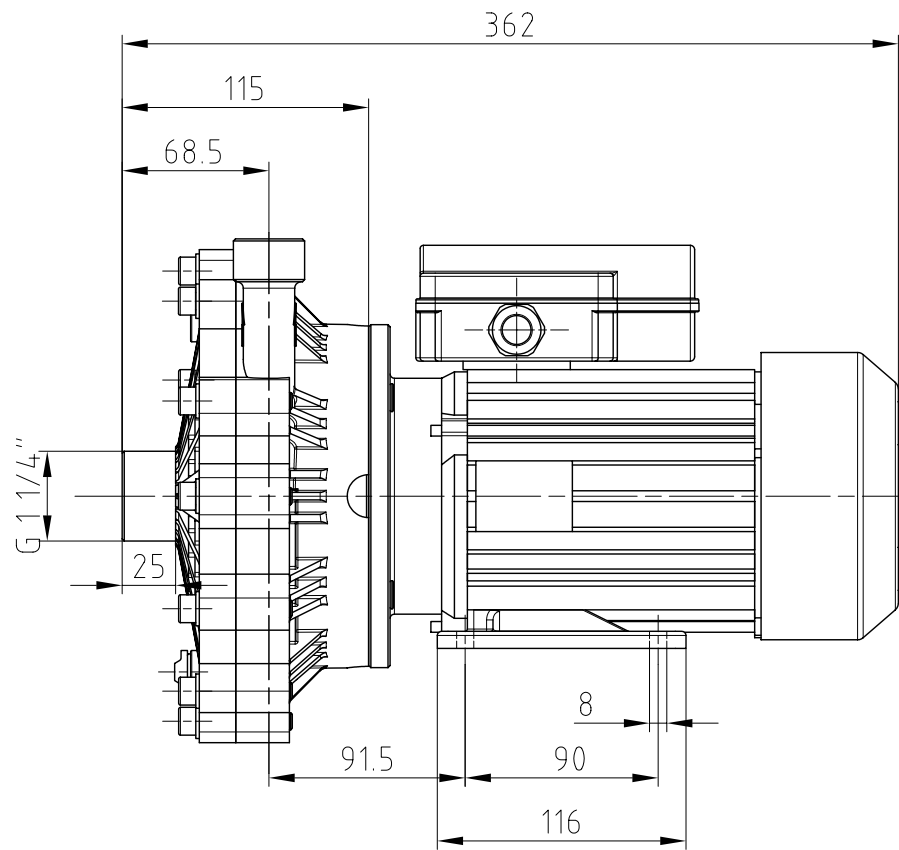

Motor - BESEL; Typ: SELhR 71-2E/442

Toleranzen DIN ISO 2768-m-K		Maßstab 1:2.5 (DIN A3)	Position	Gewicht
Oberfläche $x/\sqrt{= 12.5/}$ $y/\sqrt{= 3.2/}$ $z/\sqrt{= 0.8/}$		Werkstoff Modell Nr.		
Bearb.	Datum	Name		
Gepr.	10.03.2008	W.S.		
Norm				
 Verkaufsgesellschaft Karl Speck GmbH & Co. 91233 Neunkirchen a. Sand		Maßzeichnung BADU 73-1 Druckstutzenstellung 0° (R0)		Blatt 1
		Zchnng. Nr. D73.30.002	Ers. f.	
Zust.	Änderungen	Datum	Name	Dateiname: D73.30.002.dwg